

2SD 520 IE3

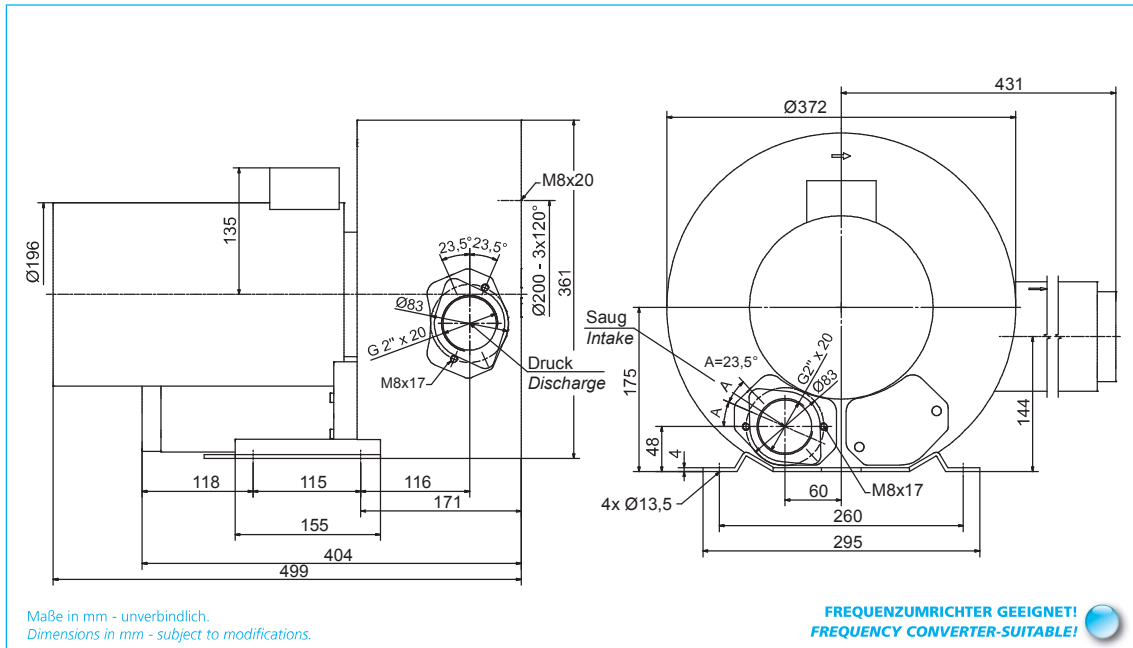

Typ Type	Effizienzklasse Efficiency class	Frequenz Frequency	Grenzwerte der Drosselkurve Überdruck Maximum performance when used as blower		Grenzwerte der Drosselkurve Unterdruck Maximum performance when used as extractor		Nennwerte des Motors Motor ratings			Schalldruckpegel Sound pressure level	Gewicht (ca.) Weight (approx.)
			\dot{V} max. \dot{V} max.	Δp_t max. Δp_t max.	\dot{V} max. \dot{V} max.	Δp_t max. Δp_t max.	Leistung Rated output	Spannung Voltage	Strom Current		
		Hz	m ³ /min	mbar	m ³ /min	mbar	kW	V	A	dB (A)	kg
2SD 520		50	3,83	450	3,83	380	3,00	230/400	9,90/5,70	72	53
		60	4,58	410	4,58	410	3,46	480	5,40	74	53

Überdruck / Pressure

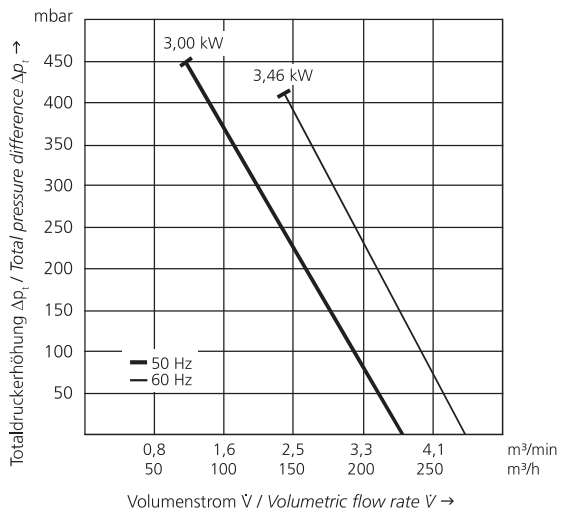

Unterdruck / Vacuum

